

Protect your customers
this storm season



Surge Protection Devices

:hager



Keeping people and property safe

Every electrical and electronic device has a specific dielectric strength against voltage fluctuations. If the voltage exceeds this strength, malfunctions and damage will occur.

Surge Protection Devices (SPDs) are designed to reduce the risk to people, property, electrical installations and connected devices from damage caused by surges, transients and lightning.

SPDs are inactive until a certain abnormal electrical energy threshold is crossed. Once the energy threshold is reached, SPDs temporarily divert damaging surge energy away from people and property.

The basics of surge protection

Various types of fluctuations commonly occur in electrical distribution systems, these fluctuations differ with respect to origin, duration, amplitude and impact.

While there is no way of predicting exactly the occurrence or intensity of surge that may affect any given installation, research and testing has identified the origins of the most damaging surges.

01 Over-voltages

Various types of power voltage surges can strike electrical and electronic systems without warning.

Depending on the cause, a surge voltage can last from a few microseconds to hours or even days, the amplitude can range from a few millivolts to thousands of volts.

SPDs are designed to mitigate transients or surges, which are high intensity, but very short duration (Millisecond or less) overvoltage events.

The measurement used for measuring levels or scale of Surge is kA (in rates per microseconds.) This is not the same as a circuit breaker short circuit withstand capacity or installation kA fault rating, (which is kA rates per second.)

02 Switching operations

Electrical grid operations, including transformer and sub-station switching operations, large electric motors or other inductive loads, sparking or faulty motor commutators, and powerline disturbances caused by construction or wind all generate electromagnetic pulses, also known as Switching Electro Magnetic Pulses (SEMPs for short)

SEMPs are short-lived but can generate extremely high currents, which in turn can lead to induced voltage surges that spread through electrical conductors, and throughout electrical systems, damaging components.

03 Lightning strikes

Lightning electromagnetic pulses (LEMPs for short) have the greatest destructive power of all voltage surges. They provoke transient over voltages which can span great distances and are often associated with high-amplitude surge currents.

An indirect lightning strike can still lead to a surge of several kilovolts with a surge current of thousands of amps.

Despite their very brief duration, from a microsecond to several hundred microseconds, lightning strikes can carry enough energy to lead to failure or the outright destruction of the affected installation



The rules and standards around Surge Protection Devices

Our SPDs have been designed to comply to AS/NZS, IEC and other standards – additional information is presented in the technical pages of this document.

The AS/NZS 3000: 2018 ‘Wiring rules’ and AS1768:2021 ‘Lightning protection’ are the two most relevant Australian standards for SPD guidance, selection and installation.



It is currently not mandatory to install SPDs in Australia. However AS/NZS 3000: 2018, Appendix F suggests SPD installation under certain criteria. One or more of the following conditions could warrant the installation of SPDs in areas:

- (a) Where lightning is prevalent.
- (b) Where power disturbances are frequent, for example, in industrial areas.
- (c) Where the site is at the end of long overhead powerlines.
- (d) Where the site is exposed, for example, on a hill.
- (e) Where sites may be many hundreds of metres apart, for example, in outer suburban or rural areas.
- (f) Where the site contains sensitive electronic equipment, for example, a home office, home theatre, computer network, etc.

An installation or building cannot be guaranteed as fully protected from a direct lightning strike or thunderstorm by installation of SPDs alone – lightning and surge protection especially in very high-risk areas or for particularly sensitive installations requires an engineered solution.

The three types of Surge Protection Devices

International standards classify SPDs as belonging to different 'Types', depending on characteristics and discharge capacity,

We offer Type 1, Spark Gap and Type 2 Surge Protection Devices; these products are designed to be permanently installed by a licensed electrician. Type 3 device are removable single socket or power board devices, available at retail outlets commonly used for limited protection of computer and audio-visual equipment.

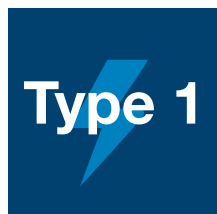

Lightning protection

Diverts the energy content of the lightning and reduces the residual voltage to values $< 6,000 - 1,300$ V.

Type 1 SPD

Recommended installations at risk of lightning strike is characterized by a $10/350$ μ s current wave.

Installation: Protection is provided when lightning currents couple into the equipotential bonding conductor of the low-voltage system, via the earth or parts of the external lightning protection system. Installed in buildings with overhead line feed and/or external lightning protection systems, in the main power supply as close as possible to the feeder before the meter, thus preventing lightning current spread.

Note, Type 1 SPDs need to be installed with Type 2 SPDs.

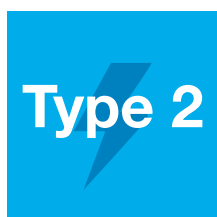

Surge protection

Reduces the remaining overvoltage to values $< 2,000 - 600$ V. The overvoltage must not exceed $4,000$ V.

Type 2 SPD

Protection system for all low voltage electrical installations and characterized by an $8/20$ μ s current wave.

Installation: Installed in electrical switchboards, these devices protect equipment by stopping the spread of overvoltages in systems and protecting loads. As second line of protection after lightning arresters, they limit surges from remote strikes or switching overvoltages. They must be installed upstream of sensitive, safety-relevant systems that can be damaged by switching overvoltages.



Socket surge protection for terminals

Reduces or secures the remaining overvoltage to values that are for end devices $< 1,500$ V.

Type 3 SPD

With low discharge capacity, Type 3 SPDs are recommended and installed as a supplement to Type 2 SPDs in the areas of sensitive loads, characterized by a combination of voltage waves ($1.2/50$ μ s) and current waves ($8/20$ μ s).

Installation: Installed near the protected device, typically at the socket.

Surge Protection technology from a single source

With the Hager SPD range, it is easy to select appropriate SPD products, from simple residential installations, to large commercial buildings with multiple switchboards, that require a complex cascading surge protection system.

To simplify SPD selection and cascading, we use the following terminology:

Spark Gap, Very Coarse, Coarse, Medium and Fine



01

'Spark Gap' Lightning arrestors. (Type 1) used in installations with conductive, direct or very frequent lightning activity. Test wave 10/350µs.



02

'Very Coarse' 100kA surge arrestors (Type 2) Suitable for large buildings and installations or areas with high risk of induced lightning or switching transients. Test wave 8/20µs.



03

'Coarse' 65kA surge arrestor (Type 2) suitable for areas with medium risk of conducted lightning and induced switching transients. Test wave 10/350µs and 8/20µs.



04

'Medium' 40kA Surge arresters (Type 2) are installed in installations with low risk of lightning and induced switching transients, typically urban residential installations. Test wave 8/20 μ s.



05

'Fine' 8kA (Type 2) Surge arresters are used for final sub circuit and device protection. Installed only in conjunction with other upstream surge protection devices. Test wave 8/20 μ s.

Quick selection guide for SPDs

We provide a simplified four part guide to select appropriate SPDs:

Part 1 - Direct or frequent lightning protection

Lightning has the highest potential for surge damage. The criteria for installing a dedicated lightning protective product is through the following questions:

- Is the installation in a lightning prone area?
- Is the installation adjacent to tall structures, tall trees or near a hill top?
- Does the installation contain a lightning rod?

If the answer is YES to any of the above, we recommend installation of a 'Spark Gap' device as the initial component of the SPD system.

We offer the SPA range of Spark Gap devices:

- For three phase, the SPA412A
- For single phase, the SPA212A

Part 2 - Indirect Lightning and Transient Protection

To ensure protection of an installation, it is vital to have adequate protection from the harmful effect of indirect or nearby lightning transients. These transients are commonly introduced into an installation from nearby lightning strikes usually from thunder storms.

Thunder Day Map

This map illustrates the lightning activity across Australia and is based upon the 'Thunder Day Map' that appears in AS/NZS 1768. This map is based on Bureau of Meteorology data.

As indicated, Australia is split into three zones of activity.

To choose the appropriate indirect lightning protection, it is important to determine what region the installation is located in:

- 1** Zone 1 - Install **'Coarse'** surge protection and cascading **'Medium'** and **'Fine'** surge protection.
- 2** Zone 2 - Install **'Medium'** surge protection and additional cascaded Fine protection for critical sub circuits
- 3** Zone 3 - Install **'Medium'** surge protection and consider **'Fine'** surge protection for protecting final circuits.



Part 3 - Surrounding infrastructure

Aside from geographic location, the type of installation and the impact of surrounding infrastructure should be considered. An installation in any of the lightning zones shown may require additional or upgraded protection from non-lightning sources of surge.

- **Is the installation supplied by exposed or long power lines or sub-mains? i.e. rural or large commercial estate**
- **Is the installation near a source of man-made switching transients; power plants or substations, or part of a large industrial or commercial zone with large motors?**
- **Is the electricity supply unreliable? - are there frequent blackouts or brownouts?**

If the answer is YES to any of the above, the SPD system selected in Part 2 should be upgraded to a higher rating.

Part 4 - Fine Protection

By installing supplementary cascaded 'Fine' surge protection, the protection of connected devices and appliances can be ensured. Our 'Fine' SPDs should only be installed to provide supplementary protection - a higher rated SPD must be installed upstream of 'Fine' protection.

- **Is the circuit longer than 10 metres, or does it leave the building? e.g. External signage, garden or pool sheds, pumps, illumination and security systems.**
- **Does a sub-board or sub-circuit contain expensive or critical electronic devices? e.g. OLED and LED TV's, PCs, NAS, security cameras and alarms, home theatre or high end audio equipment, electronic appliances with variable drives or inverter technology, mobility or medical equipment, battery or EV chargers.**

If the answer is YES to any of the above, we recommend installing supplementary 'Fine' protection.

- Install a SPB208D for single phase final circuits.
- Install a SPB408D for three phase final circuits.

For definitive requirements for installation of Surge Protection Devices, please refer to the latest version of AS:1768 and AS:3000.

Installation examples:

- **For rural, exposed or dispersed multi-building properties**
A cascading surge protection system should be installed, starting with 'Very Coarse' and a 'Spark Gap' at the Point of Supply / Main Switch Board (MSB), then 'Coarse' for Major Sub-mains and detached buildings, followed by 'Medium' at Distribution Boards or Loadcentres and supplementary 'Fine' for any long sub-circuits that have expensive or critical electronic equipment.
- **For commercial buildings and apartments**
Properties should have cascading surge protection installed, with 'Very Coarse' or 'Coarse' at the MSB, 'Medium' for any Sub-mains or Distribution Boards and ideally supplementary 'Fine' protection in Loadcentres. If SPD installation at the MSB is not possible, a higher rated SPD should be considered for the tenancy point of supply.
- **For urban residential and light commercial premises**
We recommend 'Medium' protection at the MSB – however in zones with increased lightning exposure or proximity to industrial and commercial sites, upgrading to 'Coarse' protection with cascading is recommended.



Residential Surge Protection

Selection and Application

Risk:	Highest		High		Medium				Lowest	
Residential applications										
Lightning Risk:	- Highly exposed to lightning		- Somewhat exposed to lightning		- Rarely exposed to lightning with underground service entrance, and short distance to neighbours				- Supplementary protection for final circuits with expensive, critical or important equipment	
Other Surge Risk Factors:	<ul style="list-style-type: none"> - Highly exposed to lightning - Point of supply entry for highly exposed, lightning prone sites including on hills and ridges, by tall trees or structures or connected by long overhead service power lines - Any installation with a Lightning Rod, LPS or Spark Gap Device - Proximity to very large motors or transformers; usually industrial sites, power plants or substations 		<ul style="list-style-type: none"> - Somewhat exposed to lightning - Proximity to industrial or large commercial sites that have or induce transients from large transformers or motors. - Or supplied by long service supply cables including private power poles - Rural - Power lines: metering box, point of connection, private power pole 		<ul style="list-style-type: none"> - Rarely exposed to lightning with underground service entrance, and short distance to neighbours - Suitable for most subtropical urban and suburban homes and domestic applications - Available with (R) or without (D) contact for condition monitoring 				<ul style="list-style-type: none"> - Supplementary protection for final circuits with expensive, critical or important equipment - Equipment on long circuits or remote from other SPDs - Residential apartments or flats with computer, audio visual, measurement, and security 	
Type of Installation:	Very Coarse		Coarse		Medium				Fine	
Type of Surge Protection:	Type 1 Spark Gap Type 2 100kA		Type 2 65kA		Type 2 40kA				Type 2 8kA	
	Three phase	Single phase	Three phase	Single phase	Three phase		Single phase		Three phase	Single phase
Spark Gap Direct or frequent lightning protection	SPA412A	SPA212A	-	-	-	-	-	-	-	-
TN-C Used at or near the service supply point and MSB. If the SPD can be located within ten metres of the MEN point, select a TN-C type surge protection device.	SPB300R	SPB100R	SPB365R	SPB165R	SPB340D	SPB340R	SPB140D	SPB140R	-	-
TN-S / TT Used after or downstream from the MSB or Switchboard MEN and in separate Neutral-Earth switchboard solutions.	SPB400R	SPB200R	SPB465R	SPB265R	SPB440D	SPB440R	SPB240D	SPB240R	SPB408D	SPB208D



Commercial Surge Protection

Commercial Surge Selection and Application

Risk:	Highest	High	Medium	Lowest						
Residential applications										
Lightning Risk:	- Highly exposed to lightning	- Somewhat exposed to lightning	- Rarely exposed to lightning with underground service entrance, and short distance to neighbours	- Supplementary protection for final circuits with expensive, critical or important equipment						
Other Surge Risk Factors:	<ul style="list-style-type: none"> - Highly exposed to lightning - Point of supply entry for highly exposed, lightning prone sites including on hills and ridges, by tall trees or structures or connected by long overhead service power lines - Any installation with a Lightning Rod, LPS or Spark Gap Device - Proximity to very large motors or transformers; usually industrial sites, power plants or substations 	<ul style="list-style-type: none"> - Somewhat exposed to lightning - Proximity to industrial or large commercial sites that have or induce transients from large transformers or motors. - Or supplied by long service supply cables including private power poles - Rural, Commercial or Large Institutional - Power lines: metering box, point of connection, private power pole 	<ul style="list-style-type: none"> - Rarely exposed to lightning with underground service entrance, and short distance to neighbours - Suitable for most subtropical urban and suburban homes and domestic applications - Suitable for cascaded use, downstream of higher rated SPDs such as in: Major Sub-mains, Distribution Boxes or Load Centres. - Available with (R) or without (D) contact for condition monitoring 	<ul style="list-style-type: none"> - Supplementary protection for final circuits with expensive, critical or important equipment - Load centres and equipment on long circuits or remote from other SPDs - Residential apartments or flats with computer, audio visual, measurement, security, laboratory and scientific equipment 						
Type of Installation:	Very Coarse	Coarse	Medium	Fine						
Type of Surge Protection:	Type 1 Spark Gap Type 2 100kA		Type 2 65kA		Type 2 40kA		Type 2 8kA			
	Three phase	Single phase	Three phase	Single phase	Three phase	Single phase	Three phase	Single phase		
Spark Gap Direct or frequent lightning protection	SPA412A	SPA212A	-	-	-	-	-	-	-	
TN-C Used at or near the service supply point and MSB. If the SPD can be located within two meters of the MEN point, select a TN-C type surge protection device.	SPB300R	SPB100R	SPB365R	SPB165R	SPB340D	SPB340R	SPB140D	SPB140R	-	-
TN-S / TT Used after or downstream from the MSB or Switchboard MEN and in separate Neutral-Earth switchboard solutions.	SPB400R	SPB200R	SPB465R	SPB265R	SPB440D	SPB440R	SPB240D	SPB240R	SPB408D	SPB208D

Modular protection devices

Surge Protection Devices (SPD)

Description

Our SPBxxx devices protect electrical and electronic equipment against transients originating from lightning and switching sources. These transients can cause premature aging of equipment, logic failures and down time, to the complete destruction of electrical components.

Installation and connection

- Very Coarse, Coarse, Medium and Fine
- Spark Gap and MOV technology
- Single phase or Three phase
- TN-C or TN-S / TT
- Part numbers ending in 'R' have a contact to allow for wiring in alarm to indicate cartridge replacement.
- Part numbers ending in 'D' have no contact.
- Replacement NE & L-PE cartridges available

Note

- SPBxxx cartridges are not compatible with legacy SPNxxx products
- **Contact wiring is different from SPNxxxR models to new SPBxxxR models**

Technical information:

[Page 19](#)



SPA212A



SPA412A

Spark Gap

Category C3 (Type 1)

Description	limp kA	Up kV	Uc V	Width	Cat ref.
For areas where lightning is frequent. Test wave 10/350µs	12.5	≤2.5	255	4 mod	SPA212A
	12.5	≤2.5	255	8 mod	SPA412A

Both the SPA212A & SPA412A have dual earth and phase / neutral terminals.

Devices are connected in both common and differential modes (L-E/NE/L-N) together with inbuilt auto protection up to 12.5kA.



SPB100R



SPB400R

Very Coarse

Category C2 (Type 2) - Supplied with remote contact

Description	iMax kA	In kA	Up kV	Uc V	Width	Cat ref.
Single phase						
SPD 1P T2 TNC 100kA Remote contact	100	40	2	320	1 mod	★ SPB100R
SPD 2P T2 TNS/TT 100kA Remote contact	100	40	2	320	2 mod	★ SPB200R
Three phase						
SPD 3P T2 TNC 100kA Remote contact	100	40	2	320	3 mod	★ SPB300R
SPD 4P T2 TNS/TT 100kA Remote contact	100	40	2	320	4 mod	★ SPB400R



SPB165R



SPB465R

Coarse

Category C2 (Type 2) - Supplied with remote contact

Description	limp kA	iMax kA	In kA	Up kV	Uc V	Width	Cat ref.
Single phase							
SPD 1P T2 TNC 65kA Remote contact	12.5	65	20	1.45	320	1 mod	✗ SPN165R → ★ SPB165R
SPD 2P T2 TNS/TT 65kA Remote contact	12.5	65	20	1.45	320	2 mod	★ SPB265R
Three phase							
SPD 3P T2 TNC 65kA Remote contact	12.5	65	20	1.45	320	3 mod	★ SPB365R
SPD 4P T2 TNS/TT 65kA Remote contact	12.5	65	20	1.45	320	4 mod	★ SPB465R

Description

Our SPBxxx devices protect electrical and electronic equipment against transients originating from lightning and switching sources. These transients can cause premature aging of equipment, logic failures and down time, to the complete destruction of electrical components.

Installation and connection

- Very Coarse, Coarse, Medium and Fine
- Spark Gap and MOV technology
- Single phase or Three phase
- TN-C or TN-S / TT
- Part numbers ending in 'R' have a contact to allow for wiring in alarm to indicate cartridge replacement.
- Part numbers ending in 'D' have no contact.
- Replacement L-N cartridges available

Note

- SPBxxxx cartridges are not compatible with legacy SPNxxxx products
- **Contact wiring is different from SPNxxxR models to new SPBxxxR models**

Technical information:

[Page 20](#)

Medium

Category B and C1 (Type 2)

Description	iMax kA	In kA	Up kV	Uc V	Width	Cat ref.
Single phase						
SPD 1P T2 TNC 40kA	40	20	1.35	275	1 mod	x SPN140D → ★ SPB140D x SPN115D
SPD 1P T2 TNC 40kA Remote contact	40	20	1.35	275	1 mod	x SPN140R → ★ SPB140R x SPN115R
SPD 2P T2 TNS/TT 40kA	40	20	1.35	275	2 mod	★ SPB240D
SPD 2P T2 TNS/TT 40kA Remote contact	40	20	1.35	275	2 mod	★ SPB240R
Three phase						
SPD 3P T2 TNC 40kA	40	20	1.35	275	3 mod	★ SPB340D
SPD 3P T2 TNC 40kA Remote contact	40	20	1.35	275	3 mod	★ SPB340R
SPD 4P T2 TNS/TT 40kA	40	20	1.35	275	4 mod	★ SPB440D
SPD 4P T2 TNS/TT 40kA Remote contact	40	20	1.35	275	4 mod	★ SPB440R



SPB140D



SPB440R

Fine

Category A (Type 2) - Supplied without remote contact

Description	iMax kA	In kA	Up kV	Uc V	Width	Cat ref.
Single phase						
SPD 2P TNS/TT 8 kA	8	2	0.9	275	2 mod	x SPN208D → ★ SPB208D
Three phase						
SPD 4P TNS/TT 8 kA	8	2	0.9	275	4 mod	x SPN408D → ★ SPB408D



SPB208D



SPB408D

Modular protection devices

Surge Protection Devices (SPD)

Description

Our SPBxxxx Surge Protection Device replacement cartridges and bases are IP2X. This allows for simple 'hot swap' remove and replacement of expended cartridges.

- SPD cartridges should be replaced when the visual indicator changes to a bright 'Red'.
- Replacement cartridges are available for all different ratings and types
- A keying system exists to prevent a line (L-N) cartridge being interchanged by mistake with a neutral one (N-PE) and vice versa.
- Three phase SPD requires 3x L-N
- SPBxxxx cartridges are not compatible with legacy SPNxxxx products
- **SPD 'R' model contactor wiring layout has changed for all new SPBxxxR Surge Protection Devices**



SPB065R



SPB008D

SPB Replacement Active Cartridges - L-N

For TN-S and TN-C SPD

Description	Type	iMax kA	Cat ref.
Cartridge L-N; In 40kA, I _{max} 100kA	Very Coarse	100	★ SPB010R
Cartridge L-N; In 20kA, I _{max} 65kA	Coarse	65	★ SPB065R
Cartridge L-N; In 20kA, I _{max} 40kA	Medium	40	★ SPB040R
Cartridge L-N; In 2kA, I _{max} 8kA	Fine	8	★ SPB008R

SPB Replacement Neutral Cartridges - N-PE

For TN-S SPD

Description	Type	iMax kA	Cat ref.
Cartridge N-PE; In 20kA, I _{max} 100kA	Very Coarse	100	★ SPB010N
Cartridge N-PE; In 20kA, I _{max} 65kA	Coarse	65	★ SPB065N
Cartridge N-PE; In 20kA, I _{max} 40kA	Medium	40	★ SPB040N



SPB010N



SPB040N

Electrical characteristics

Ref	Spark Gap SPA212A	Spark Gap SPA412A	Very Coarse SPB100R	Very Coarse SPB200R	Very Coarse SPB300R	Very Coarse SPB400R	Coarse SPB165R	Coarse SPB265R	Coarse SPB365R	Coarse SPB465R
AS/NZ1768 Location Category	Cat C3	Cat C3	Cat C2	Cat C2	Cat C2	Cat C2	Cat C2	Cat C2	Cat C2	Cat C2
AS/NZ1768: Zone Boundary	LPZ 0A - LPZ 1	LPZ 0A - LPZ 1	LPZ 0A - LPZ 1	LPZ 0A - LPZ 1	LPZ 0A - LPZ 1	LPZ 0A - LPZ 1	LPZ 0A - LPZ 1	LPZ 0A - LPZ 1	LPZ 0A - LPZ 1	LPZ 0A - LPZ 1
EN 61643 SPD Type	T1	T1	T2	T2	T2	T2	T2	T2	T2	T2
IEC 61643-1 SPD Class	I	I	II	II	II	II	II	II	II	II
Single Max impulse (8/20 µs)	I_{max}		100kA	100kA	100kA	100kA	65kA	65kA	65kA	65kA
Nominal discharge current (8/20µs)	I_n		40kA	40kA	40kA	40kA	20kA	20kA	20kA	20kA
Pulse discharge current (10/350µs)	I_{imp}	12.5kA	12.5kA	2.5kA	2.5kA	2.5kA	2.5kA	12.5kA	12.5kA	12.5kA
Max. continuous operating voltage	U_c	255 V AC	255 V AC	320 V AC	320 V AC	320 V AC	320 V AC	320 V AC	320 V AC	320 V AC
Voltage protection (common)	U_p	2.5kV	2.5kV	2kV	2kV	2kV	2kV	1.45kV	1.45kV	1.45kV
Residual current	I_{RE}	<100mA	<100mA	<0.45 mA	<5 µA	<0.45 mA	<5 µA	<0.45 mA	<5 µA	<5 µA
Iscrr	-	-	25kA	25kA	25kA	25kA	25kA	25kA	25kA	25kA
Maximum rating MCB for overcurrent protection	125A series / 315A parallel	125A series / 315A parallel	63A "C"	63A "C"	63A "C"	63A "C"	63A "C"	63A "C"	63A "C"	63A "C"
Recommended MCB rating	63A "C"	63A "C"	63A "C"	63A "C"	63A "C"	63A "C"	40A "C"	40A "C"	40A "C"	40A "C"
Max Back-up Fuse	-	-	250A	250A	250A	250A	160A	160A	160A	160A
Recommended Back-up Fuse	-	-	63A to 125A	63A to 125A	63A to 125A	63A to 125A	63A to 125A	63A to 125A	63A to 125A	63A to 125A
Conductor Connection Capacity	Min 1.5mm ² Max 35 mm ²	Min 1.5mm ² Max 35 mm ²	Min 1.5mm ² Max 35 mm ²	Min 1.5mm ² Max 35 mm ²	Min 1.5mm ² Max 35 mm ²	Min 1.5mm ² Max 35 mm ²	Min 1.5mm ² Max 35 mm ²	Min 1.5mm ² Max 35 mm ²	Min 1.5mm ² Max 35 mm ²	Min 1.5mm ² Max 35 mm ²
Operating Temperature	-40...60 °C	-40...60 °C	-40...80 °C	-40...80 °C	-40...80 °C	-40...80 °C	-40...80 °C	-40...80 °C	-40...80 °C	-40...80 °C
Contact for Remote Monitoring	N	N	Y	Y	Y	Y	Y	Y	Y	Y
Number of modules total	4	8	1	2	3	4	1	2	3	4
Single phase	Y	-	Y	Y	-	Y	Y	-	-	Y
Three Phase	-	Y	-	-	Y	-	-	Y	Y	-
TNC	-	-	TNC	-	TNC	-	TNC	-	TNC	-
TNS/TT	-	-	-	TNS/TT	-	TNS/TT	-	TNS/TT	-	TNS/TT
Indication of SPD disconnector	Green LED on L1, L2, L3	Green LED on L1, L2, L4	Green = Good Red = Bad	Green = Good Red = Bad	Green = Good Red = Bad	Green = Good Red = Bad	Green = Good Red = Bad	Green = Good Red = Bad	Green = Good Red = Bad	Green = Good Red = Bad
L-N Replacement cartridge	-	-	SPB010R	SPB010R	SPB010R	SPB010R	SPB065R	SPB065R	SPB065R	SPB065R
N-PE Replacement cartridge	-	-	-	SPB010N	-	SPB010N	-	SPB065N	-	SPB065N
L-N	-	-	1	1	3	1	1	3	3	1
N-PE	-	-	0	1	0	1	0	1	0	1
Response time	t_A	≤100ns	≤100ns	-	-	-	-	-	-	-
Dimensions: Length, Width, Height	-	-	77.5 x 17.5 x 98.7	77.5 x 35 x 98.7	77.5 x 52.5 x 98.7	77.5 x 70 x 98.7	77.5 x 17.5 x 98.7	77.5 x 35 x 98.7	77.5 x 52.5 x 98.7	77.5 x 70 x 98.7

SPD 'R' model contactor wiring layout has changed for all new SPBxxxR SPDs.

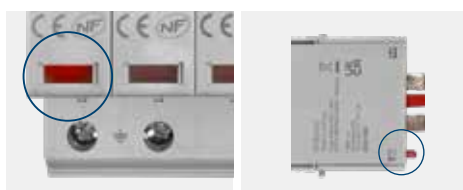
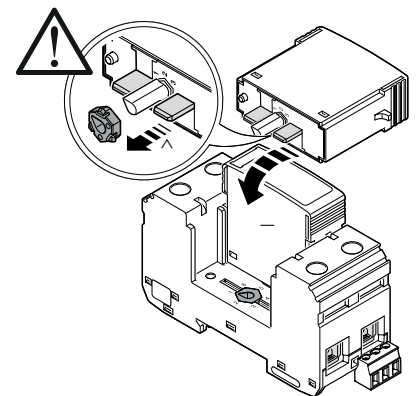
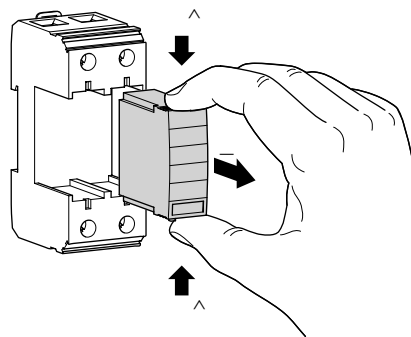
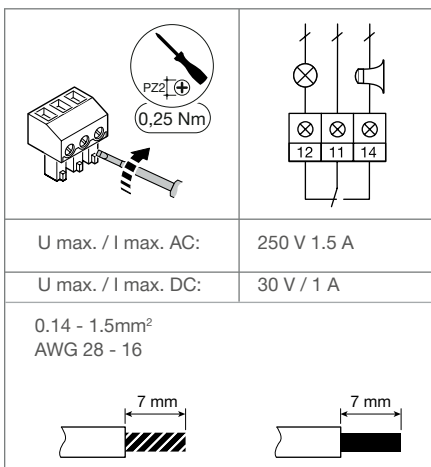

How do I know if I need to replace a SPD cartridge?

- For Very Coarse (100kA) and Coarse (65kA) SPDs - a small oval indicator will change colours from Green (Ok) to Red (Faulty).
- For Medium (40kA) and Fine (8kA) SPDs - a rectangular window is present, when this window is bright red, there is a fault.
- Please note the rectangular style fault indicators may look somewhat red, or red tinged when new.
- If the red 'pin' at the rear of the cartridge is retracted, replace the cartridge. If proud (as pictured to the left), then it is good.

Electrical characteristics

Ref	Medium SPB140D	Medium SPB140R	Medium SPB240D	Medium SPB240R	Medium SPB340D	Medium SPB340R	Medium SPB440D	Medium SPB440R	Fine SPB208D	Fine SPB408D
AS/NZ1768 Location Category	Cat C1 /B	Cat C1 /B	Cat C1 /B	Cat C1 /B	Cat C1 /B	Cat C1 /B	Cat C1 /B	Cat C1 /B	Cat A	Cat A
AS/NZ1768: Zone Boundary	LPZ 1 - LPZ OB	LPZ 1 - LPZ OB	LPZ 1 - LPZ OB	LPZ 1 - LPZ OB	LPZ 1 - LPZ OB	LPZ 1 - LPZ OB	LPZ 1 - LPZ OB	LPZ 1 - LPZ OB	LPZ 2 - LPZ 3	LPZ 2 - LPZ 3
EN 61643 SPD Type	T2	T2	T2	T2	T2	T2	T2	T2	T2	T2
IEC 61643-1 SPD Class	II	II	II	II	II	II	II	II	II	II
Single Max impulse (8/20 µs)	I_{max} 40kA	40kA	40kA	40kA	40kA	40kA	40kA	40kA	8kA	8kA
Nominal discharge current (8/20µs)	I_n 20kA	20kA	20kA	20kA	20kA	20kA	20kA	20kA	2kA	2kA
Pulse discharge current (10/350µs)	I_{imp} -	-	-	-	-	-	-	-	-	-
Max. continuous operating voltage	U_c 275 V AC	275 V AC	275 V AC	275 V AC	275 V AC	275 V AC	275 V AC	275 V AC	275 V AC	275 V AC
Voltage protection (common)	U_p 1.35kV	1.35kV	1.35kV	1.35kV	1.35kV	1.35kV	1.35kV	1.35kV	0.9kV	0.9kV
Residual current	I_{FE} <0.45 mA	<0.45 mA	<5 µA	<5 µA	<0.45 mA	<0.45 mA	<5 µA	<5 µA	<5 µA	<5 µA
Iscrr	25kA	25kA	25kA	25kA	25kA	25kA	25kA	25kA	10kA	10kA
Maximum rating MCB for overcurrent protection	32A "C"	32A "C"	32A "C"	32A "C"	32A "C"	32A "C"	32A "C"	32A "C"	32A "C"	32A "C"
Recommended MCB rating	32A "C"	32A "C"	32A "C"	32A "C"	32A "C"	32A "C"	32A "C"	32A "C"	32A "C"	32A "C"
Max Back-up Fuse	125A	125A	125A	125A	125A	125A	125A	125A	125A	125A
Recommended Back-up Fuse	32A to 100A	32A to 100A	32A to 100A	32A to 100A	32A to 100A	32A to 100A	32A to 100A	32A to 100A	20A to 32A	20A to 32A
Connection Capacity	Min 1.5mm ² Max 35 mm ²	Min 1.5mm ² Max 35 mm ²	Min 1.5mm ² Max 35 mm ²	Min 1.5mm ² Max 35 mm ²	Min 1.5mm ² Max 35 mm ²	Min 1.5mm ² Max 35 mm ²	Min 1.5mm ² Max 35 mm ²	Min 1.5mm ² Max 35 mm ²	Min 1.5mm ² Max 35 mm ²	Min 1.5mm ² Max 35 mm ²
Operating Temperature	-40...80 °C	-40...80 °C	-40...80 °C	-40...80 °C	-40...80 °C	-40...80 °C	-40...80 °C	-40...80 °C	-40...80 °C	-40...80 °C
Contact for Remote Monitoring	N	Y	N	Y	N	Y	N	Y	N	N
Number of modules total	1	1	2	2	3	3	4	4	2	4
Single phase	Y	Y	Y	Y	-	-	-	-	Y	-
Three Phase	-	-	-	-	Y	Y	Y	Y	-	Y
TNC	TNC	TNC	-	-	TNC	TNC	-	-	-	-
TNS/TT	-	-	TNS/TT	TNS/TT	-	-	TNS/TT	TNS/TT	TNS/TT	TNS/TT
Indication of SPD disconnecter	Bright Red = Replace	Bright Red = Replace	Bright Red = Replace	Bright Red = Replace	Bright Red = Replace	Bright Red = Replace	Bright Red = Replace	Bright Red = Replace	Bright Red = Replace	Bright Red = Replace
L-N Replacement cartridge	SPB040D	SPB040D	SPB040D	SPB040D	SPB040D	SPB040D	SPB040D	SPB040D	SPB008D	SPB008D
N-PE Replacement cartridge	-	-	SPB040N	SPB040N	-	-	SPB040N	SPB040N	SPB040N	SPB040N
L-N	1	1	1	1	3	3	3	3	1	3
N-PE	0	0	1	1	0	0	1	1	1	1
Dimensions: Length, Width, Height	65.7 x 17.5 x 98.7	65.7 x 17.5 x 98.7	65.7 x 35 x 98.7	65.7 x 35 x 98.7	65.7 x 52.5 x 98.7	65.7 x 52.5 x 98.7	65.7 x 70 x 98.7	65.7 x 70 x 98.7	58 x 35 x 90	65.7 x 70 x 90

SPD 'R' model contactor wiring layout has changed for all new SPBxxxR SPDs.

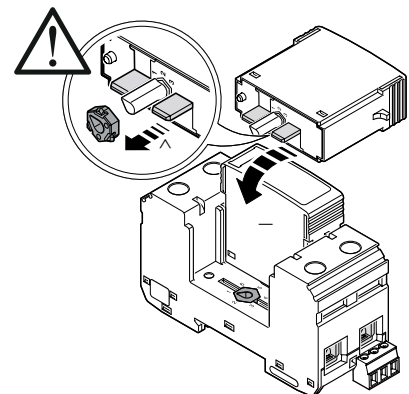
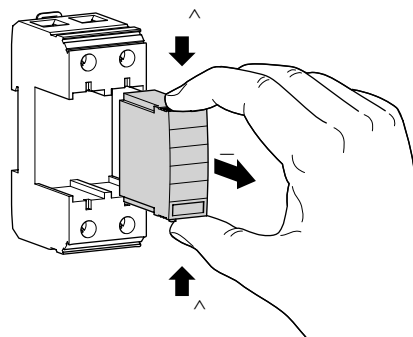
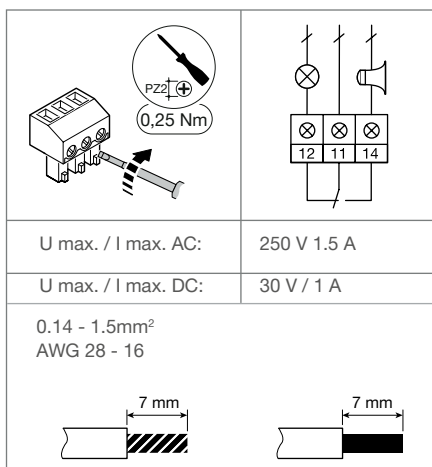

How do I know if I need to replace a SPD cartridge?

- For Very Coarse (100kA) and Coarse (65kA) SPDs - a small oval indicator will change colours from Green (Ok) to Red (Faulty).
- For Medium (40kA) and Fine (8kA) SPDs - a rectangular window is present, when this window is bright red, there is a fault.
- Please note the rectangular style fault indicators may look somewhat red, or red tinged when new.
- If the red 'pin' at the rear of the cartridge is retracted, replace the cartridge. If proud (as pictured to the left), then it is good.

Electrical characteristics

Ref		Very Coarse	Very Coarse	Coarse	Coarse	Medium	Medium	Fine
		SPB010R	SPB010N	SPB065R	SPB065N	SPB040D	SPB040N	SPB008D
AS/NZ1768 Location Category		Cat C3	Cat C3	Cat C2	Cat C2	Cat C1/B	Cat C1/B	Cat CA
AS/NZ1768: Zone Boundary		LPZ 0A - LPZ 1	LPZ 0A - LPZ 1	LPZ 0A - LPZ 1	LPZ 0A - LPZ 1	LPZ 1 - LPZ OB	LPZ 1 - LPZ OB	LPZ 2 - LPZ 3
EN 61643 SPD Type		T1	T1	T2	T2	T2	T2	T2
IEC 61643-1 SPD Class		I	I	II	II	II	II	II
Single Max impulse (8/20 μs)	I_{max}	100kA	100kA	65kA	65kA	40kA	40kA	8kA
Nominal discharge current (8/20μs)	I_n	40kA	40kA	20kA	20kA	20kA	20kA	2kA
Pulse discharge current (10/350μs)	I_{imp}	2.5kA	2.5kA	-	-	-	-	-
Max. continuous operating voltage	U_c	320 V AC	260 V AC	275 V AC	260 V AC	275 V AC	260 V AC	275 V AC
Voltage protection (common)	U_p	2kV	1.5kV	1.35kV	1.5kV	1.35kV	1.5kV	0.9kV
Residual current	I_{RE}	-	-	-	-	-	-	-
Iscrr		-	-	-	-	-	-	-
Maximum rating MCB for overcurrent protection		-	-	-	-	-	-	-
Recommended MCB rating		-	-	-	-	-	-	-
Max Back-up Fuse		-	-	-	-	-	-	-
Recommended Back-up Fuse		-	-	-	-	-	-	-
Connection Capacity		-	-	-	-	-	-	-
Operating Temperature		-40...80 °C	-40...80 °C	-40...80 °C	-40...80 °C	-40...80 °C	-40...80 °C	-40...80 °C
Remote Contact		-	-	-	-	-	-	-
Number of modules total		1	1	1	1	1	1	1
Single phase		-	-	-	-	-	-	-
Three Phase		-	-	-	-	-	-	-
TNC		-	-	-	-	-	-	-
TNS/TT		-	-	-	-	-	-	-
Indication of SPD disconnecter		Green = good Red = replace	Green = good Red = replace	Green = good Red = replace	Green = good Red = replace	Bright Red = Replace	Bright Red = Replace	Bright Red = Replace
L-N Replacement cartridge		-	-	-	-	-	-	-
N-PE Replacement cartridge		-	-	-	-	-	-	-
L-N		1 x L-N	-	1 x L-N	-	1 x L-N	-	1 x L-N
N-PE		-	1 x N-PE	-	1 x N-PE	-	1 x N-PE	-

Very Coarse and Coarse SPDs

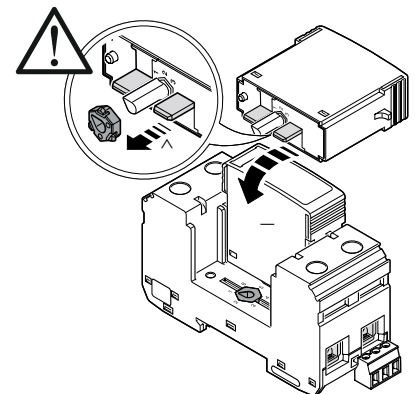
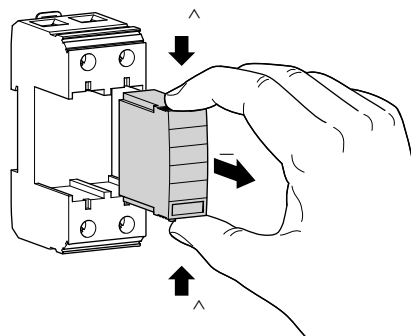
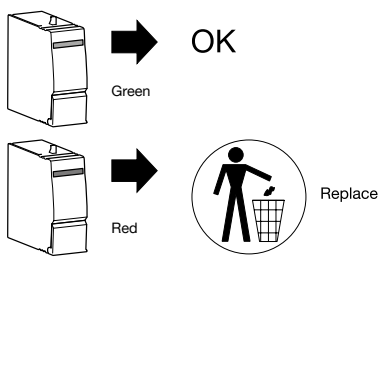

Medium and Fine SPDs

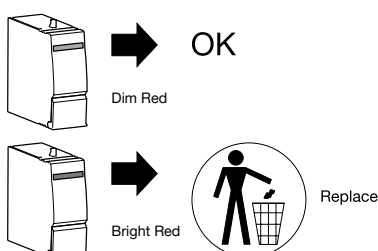

The indicator circled on the left shows this cartridge needs to be replaced, the cartridge not circled to the right of it is ok.

How to connect SPDs

Depending on the wiring and earthing system in use at the point of installation, the type and wiring configuration of the SPD can provide different protection effects.

SPDs are usually installed and wired after the installation main switch, either:

- In parallel which will keep the Installation online, but unprotected against further surge events, in the event of SPD consumption.
- In series, which will disconnect the installation in the event of SPD consumption.

Installing and wiring SPDs after the main switch, but in parallel to the incoming supply, after and in series with a dedicated SPD overcurrent protection device (fuse or MCB) is best practice in most installations.

As an analogy SPDs may be compared to fuses, in that:

- They are protective items and should be placed upstream of the of the equipment or circuits that need to be protected.
- To function correctly the level of protection needs to be selected to function both for faults and the type of equipment to be protected and to cascade appropriately with other protection devices – a higher kA rated device or ‘type’ is not necessarily ‘better’ at providing protection.
- They are consumable, once a certain amount or intensity of surges have been diverted, they will need to be replaced. This is the benefit of SPDs with replaceable cartridge systems and alarms. They indicate when the SPD needs to be replaced and swapping of spent cartridges is easy.

Earthing guide for SPDs

The correct selection of the appropriate SPD is based on the location and style of earthing system present in the installation, and location of the SPD in the installation.

Our SPDs are available in two earthing or 'network configurations':

1. TN-C

A TN-C earthing system is commonly present between the transformer that supplies the site and the installation Main Switch Board (MSB) the supply neutral and earth conductors are run together in a Protective Earth Neutral (PEN) configuration. A TN-C SPD is used for switchboards with Multiple Earthed Neutral (MEN) connection – usually the MSB.

Our TN-C SPDs are one or three modules wide and do not have a Neutral cartridge.

TN-C SPDs are commonly installed at the installation MSB.

1P - 3P (TN-C)

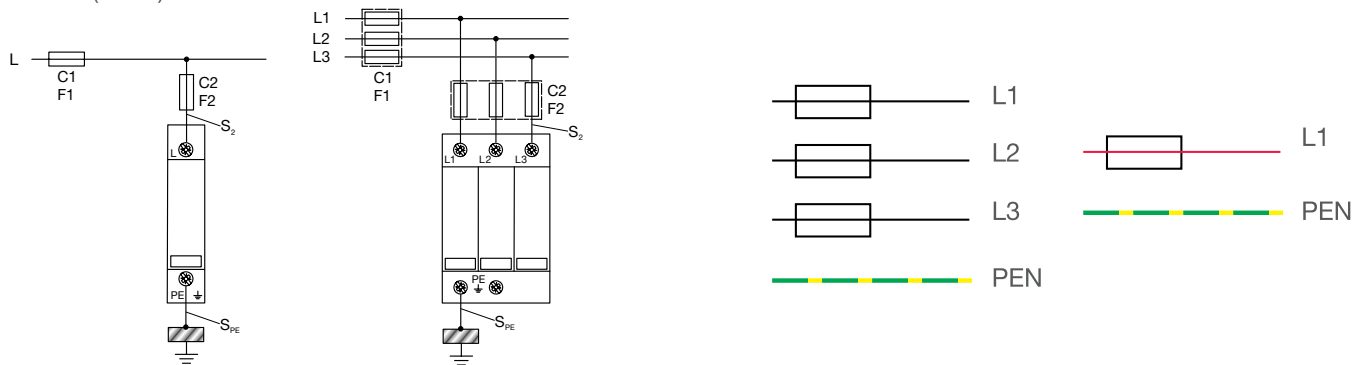

2. TN-S / TT -

A TN-S earthing system is commonly used inside the domestic installations downstream of the MEN point and for separate Neutral-Earth (non-MEN) switchboard solutions, such as commercial load centres and sub distribution where Protective Earth (PE) and Neutral (N) wiring are separated.

Our TN-S/TT SPDs are two or four modules wide and have a special Neutral module.

If an SPD is installed further than 10 metres from a MEN link, a TN-S SPD is required.

2P - 4P (TN-S/TT)

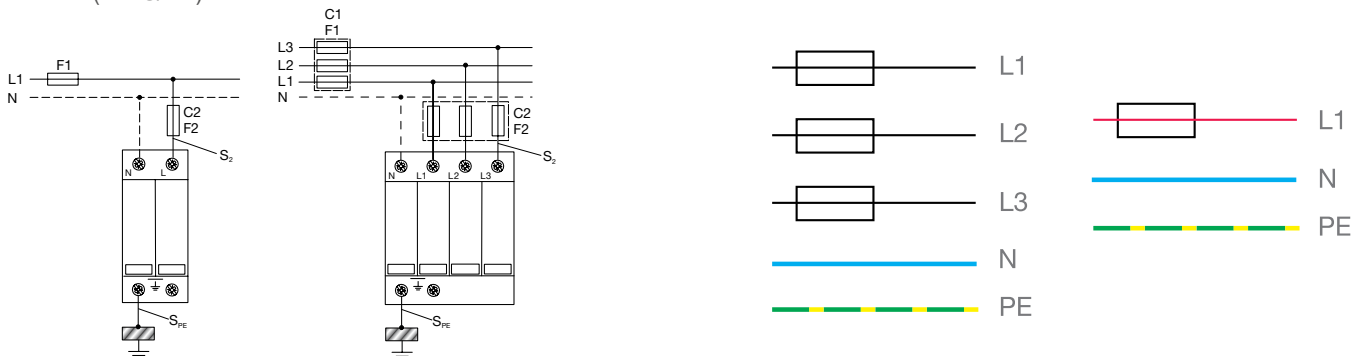

Required conductor cross-sections for connection of the SPD

SPD to Earth

Cables between the protective device and the main earthing bar and/or the main earthing electrode /stake must have the following minimum cross-sections:

- 16 mm² copper or equivalent conductor cross-section for Spark Gap SPDs
- 6 mm² copper or conductor cross-section of the same
- conductivity for all of our other SPDs.

For our Medium and Fine SPDs, it is sufficient to make connection to the main earth bar, if the earth connection is short and the earthing is confirmed as good, as per AS1768:2021.

Our Spark Gap devices must be connected to the main earth bar and should also be suitably connected to the main earth stake by a separate 16 mm² cable, kept as short as possible, and away from other conductors – this is for diverting lightning energy to earth.

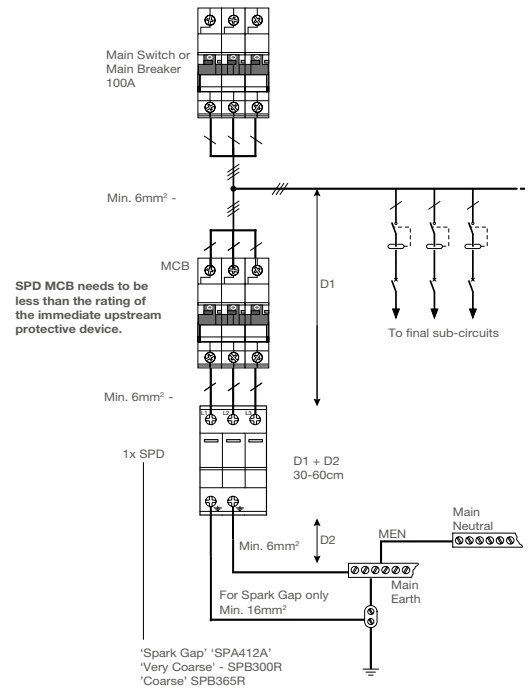

Phase and Neutral to SPD

The conductors between the SPD and the line (Active / Phase and Neutral) conductors must be designed in accordance with the Australian wiring rules, including the prospective short-circuit current, and deratings.

We suggest the following minimum cross-sections:

- Minimum 6 mm² CU for SPDs.

Example wiring diagrams

Surge protection single phase layout example in Main switchboard with MEN link

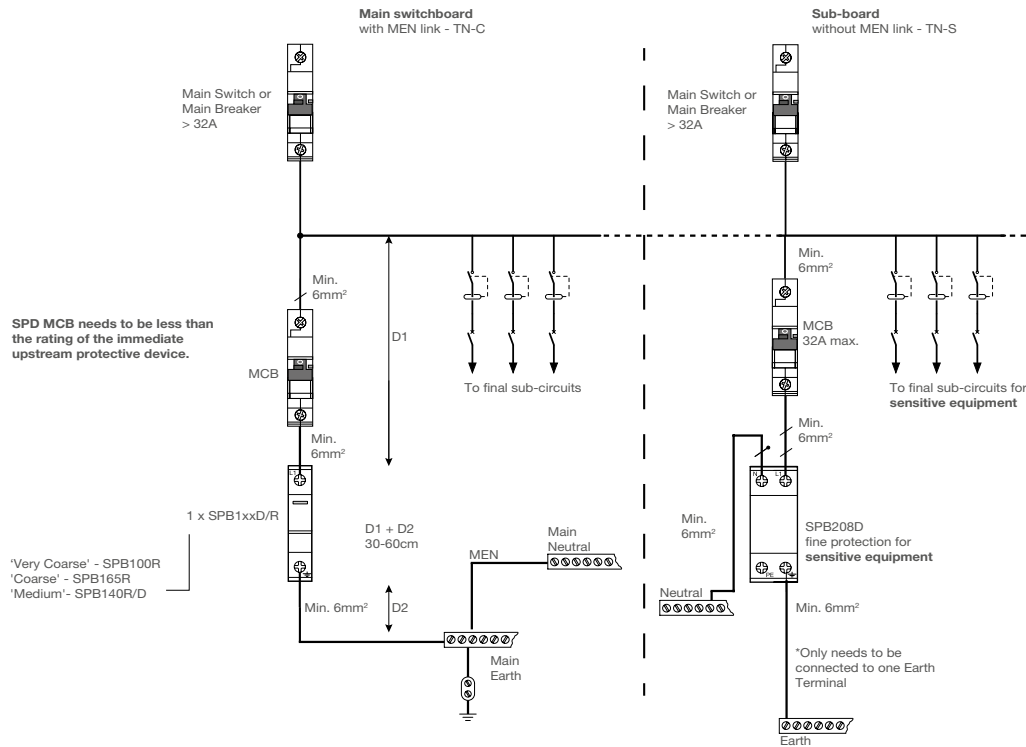

Surge protection three phase layout example in Main switchboard with MEN link

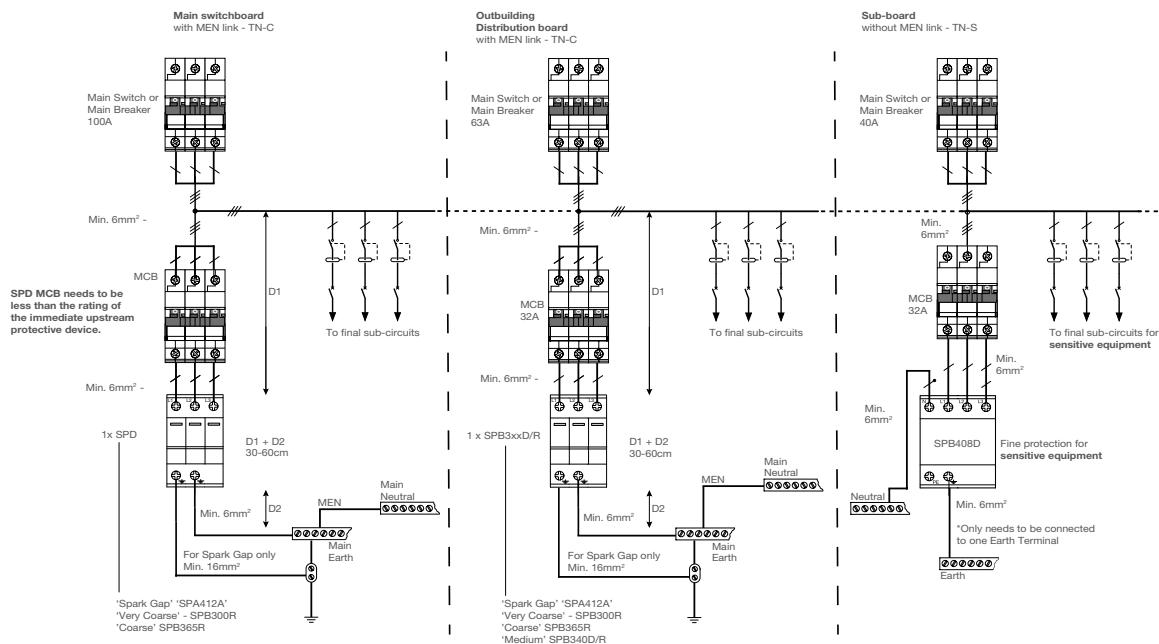

SPD cascading in installations

Example of SPD cascading in multiple distribution point installation

– this could be applied for a large rural property, commercial campus or large residential site, where there are separate outbuildings.

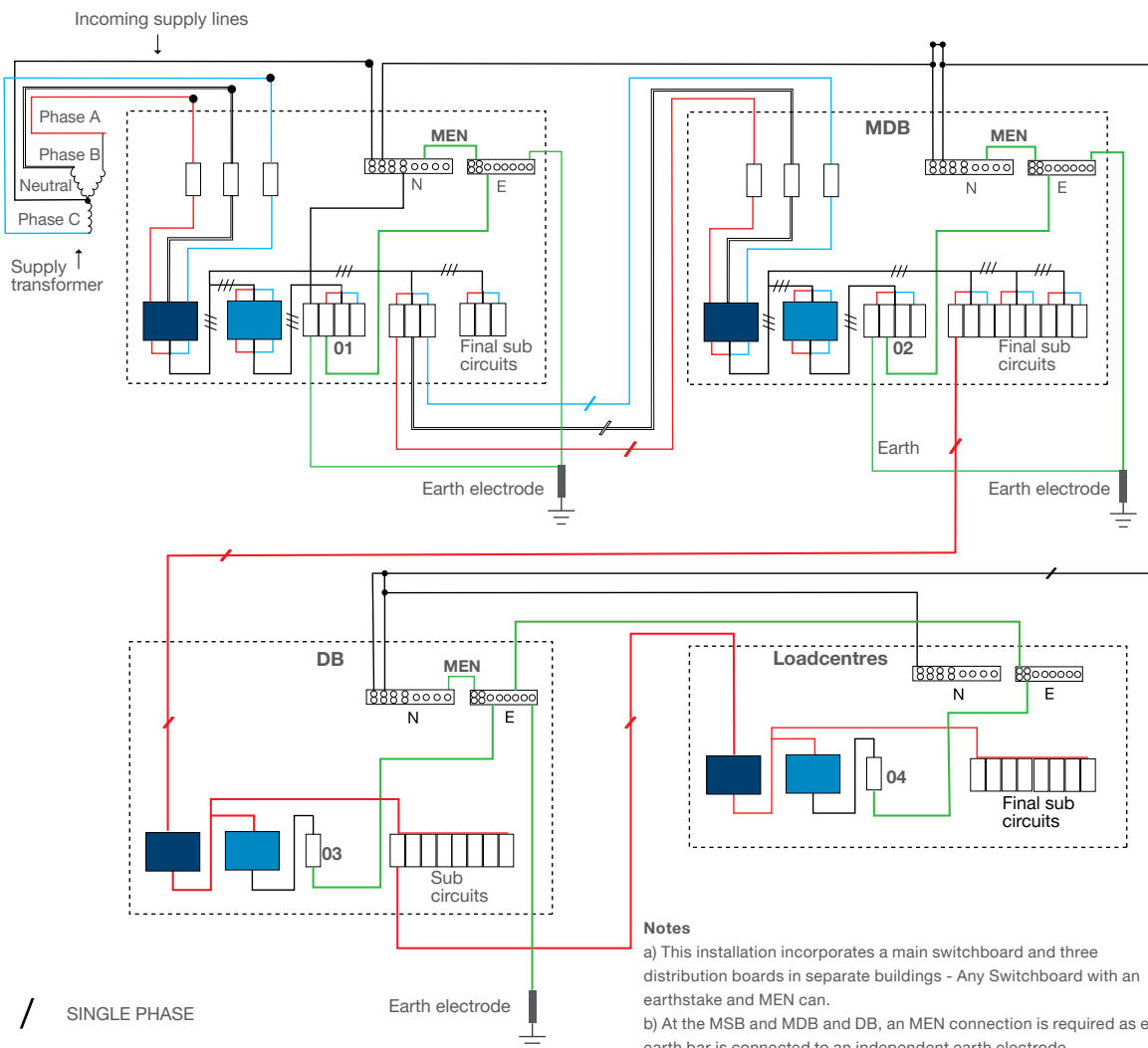

- / SINGLE PHASE
- /// THREE PHASE
- MAIN SWITCH
- SPD MCB-FUSE
- 01** SPD VERY COARSE
- 02** SPD COARSE
- 03** SPD MEDIUM
- 04** SPD FINE

Notes

- a) This installation incorporates a main switchboard and three distribution boards in separate buildings - Any Switchboard with an earthstake and MEN can.
- b) At the MSB and MDB and DB, an MEN connection is required as each earth bar is connected to an independent earth electrode.
- c) There is no MEN connection at the loadcentre, as the earthing is connected directly to the installation earthing system, this is known as a laid up earth in the sub-main.
- d) The method of earthing a distribution board in an outbuilding, must comply with either the system described in b) or in c), as above.
- e) The neutral conductor supplying MDB and DB does not rely on a terminal connection at a distribution board in outbuilding 1 for its continuity - that is to say the neutrals are bonded and cannot be separated.

Wiring Rules Clauses (specific to this diagram)

- 1.4.83 Definition of the MEN system
- 5.3.3 Size of Earthing Conductors
- 5.3.3.2 Main Earthing Conductors
- 5.5.3.1 Outbuildings
- 1.4.88 Definition of outbuildings
- 1.4.89 Combined outbuildings

Frequently asked questions

How often should I inspect Surge Protective Devices?

We suggest inspection annually and after any storm, lightning or power failure event. Ongoing, effective operation can be confirmed installing SPDs with a remote contact connected to an audio or visual alarm to signal SPD status.

What test or inspection should be carried out Surge Protective Devices?

Earthing resistance test to confirm low resistance path to earth.

Does the install comply with the following requirements?

- Minimum conductor cross-sectional area
- Correct size and function of overcurrent Fuse or MCB
- Surge protective devices in good mechanical condition, cartridges aligned and seated.
- Any available status indicators show functionality – there should be no prominent RED indicator

Do I have to use SPDs?

SPDs are not currently mandatory in Australia, however installing SPDs is recommended by the wiring standard.

How many SPDs should I install?

Installing several SPD devices to create a preventative SPD system is proven to be a more effective approach to surge damage mitigation, as lightning and surges may occur anywhere in an installation. Additionally, by installing SPD in multiple locations surge damage may be mitigated from traversing further through the electrical installation, reducing or containing the overall damage.

Why do some SPDs come with a contact, and what is it for?

Our SPDs with part numbers that end in the letter 'R' have a contact, to allow for remote status indication, via wiring in an additional remote visual, audio alarm or BMS input.

Is the SPNxxx range of SPDs compatible with the new SPBxxx range?

The SPB and SPN will 'work' and cascade with each other, but the cartridges are not interchangeable, and the wiring is different layout for 'R' contacts.

Do I need an SPD with a Neutral cartridge?

Not if the SPD is a TN-C device, installed close to a MEN link.

What is the difference between a three module and four module SPDs?

Are they both suitable for three phase?

Both three and four module SPD devices are suitable for 3 phase circuits. Four module SPD devices are only required when the device is not within a 10 metre proximity to a MEN link, as the MEN link provides the required link of neutral to earth.

Do SPDs require an Australian RCM mark?

Surge devices are not in the declared list of electrical articles in Australia, and therefore do not require RCM approval.

How do I know if I need to replace an SPD cartridge?

If the colour changes to a bright Red, additionally if the 'pin' at the back of the cartridge is retracted then the cartridge should be replaced.

How do I know what SPD replacement cartridges are required?

The part number is clearly marked on the front of the device, additionally this information is the technical information provided with the device and in the following technical pages.

What size SPD overcurrent protection device (Fuse or MCB) do I need?

We provide the maximum fuse and MCB ratings for each SPD, however the selected SPD overcurrent device needs to be less than the rating of the immediate upstream protective device, e.g. The MSB Main Switch.



Hager Electro Pty Ltd

Unit 17
2-8 South Street
Rydalmere NSW 2116
hagerelectro.com.au

Nationwide sales

Phone: 1300 850 253
Fax: 1300 424 372
Email: customerservice@hagerelectro.com.au

DISCLAIMER: Whilst every effort has been made to ensure the reliability of the information is correct at time of publication, Hager cannot guarantee the accuracy of all of the information contained herein. Changes/updates brought to the attention of Hager, once verified, will be corrected in future editions.